

REVISIONS	
ISS	DESCRIPTION \ DATE

RoHS COMPLIANT

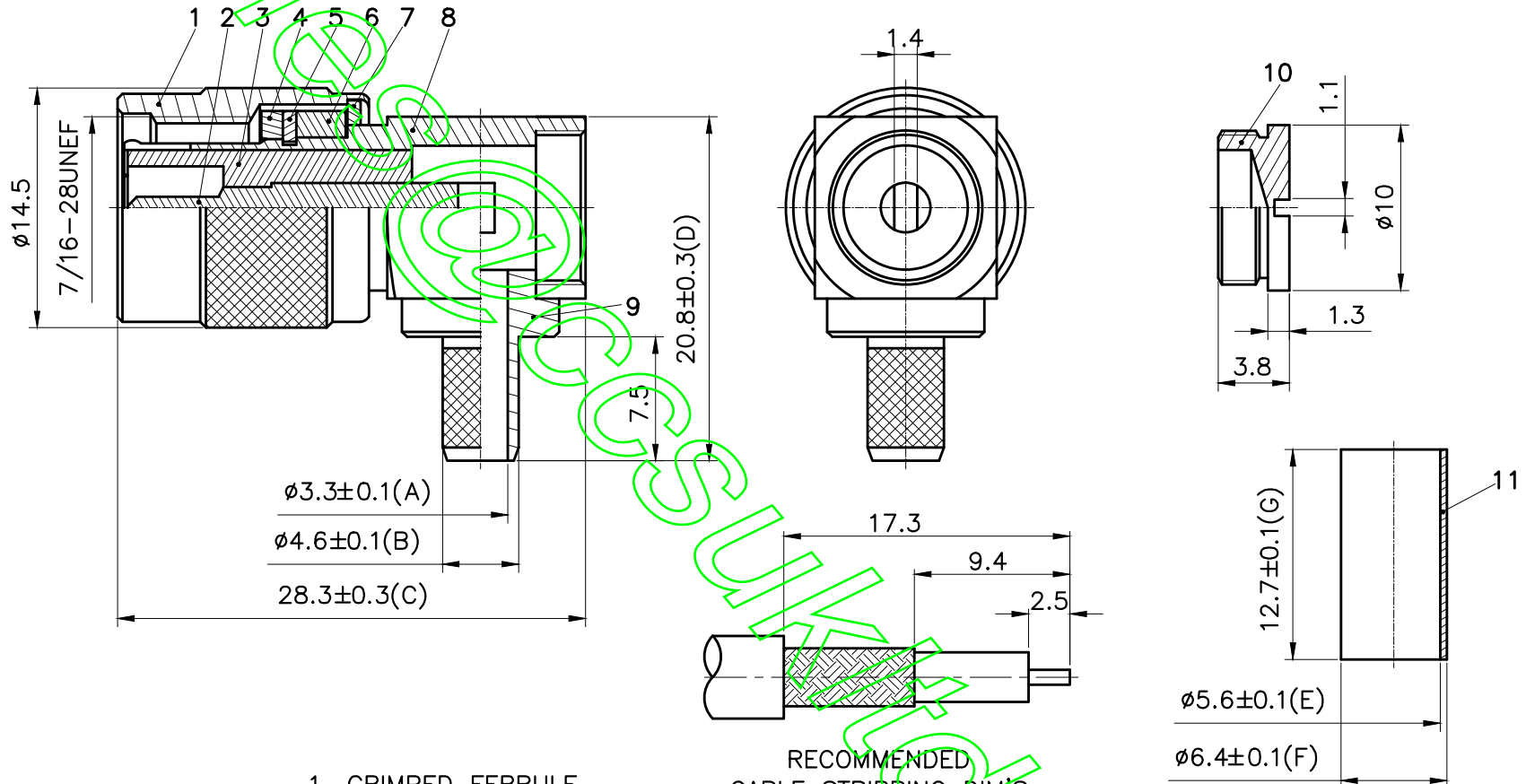

1. CRIMPED FERRULE
HEX CRIMP SIZE .213"
2. CONTACT PIN TO SOLDER



TITLE: TNC MALE RIGHT ANGLE CRIMP
 PART NO: TPRACS58
 DRAWING NO: 030

APRD:	UNLESS OTHERWISE SPECIFIED TOLERANCES 0.5-6 = ±0.2 >6-30 = ±0.4 >30-120 = ±0.6 >120-315 = ±1 >315-1000 = ±1.6 ANGLES = ±5°
CHKD:	
DR:	
DATE: 02/20/03"	UNIT: mm
SHEET: .	SCALE: 2.5/1

NO.	DESCRIPTION	MATERIAL	FINISH
11	FERRULE	BRASS	NICKEL
10	NUT	BRASS	NICKEL
9	BODY	BRASS	NICKEL
8	BODY	BRASS	NICKEL
7	WASHER	STEEL	NICKEL
6	RING	BRASS	NICKEL
5	WASHER	STEEL	NICKEL
4	GASKET	RUBBER	RED
3	INSULATOR	DELIN	WHITE
2	CONTACT PIN	BRASS	GOLD
1	SHELL	BRASS	NICKEL