

REVISIONS	
ISS	DESCRIPTION\DATE

RoHS COMPLIANT

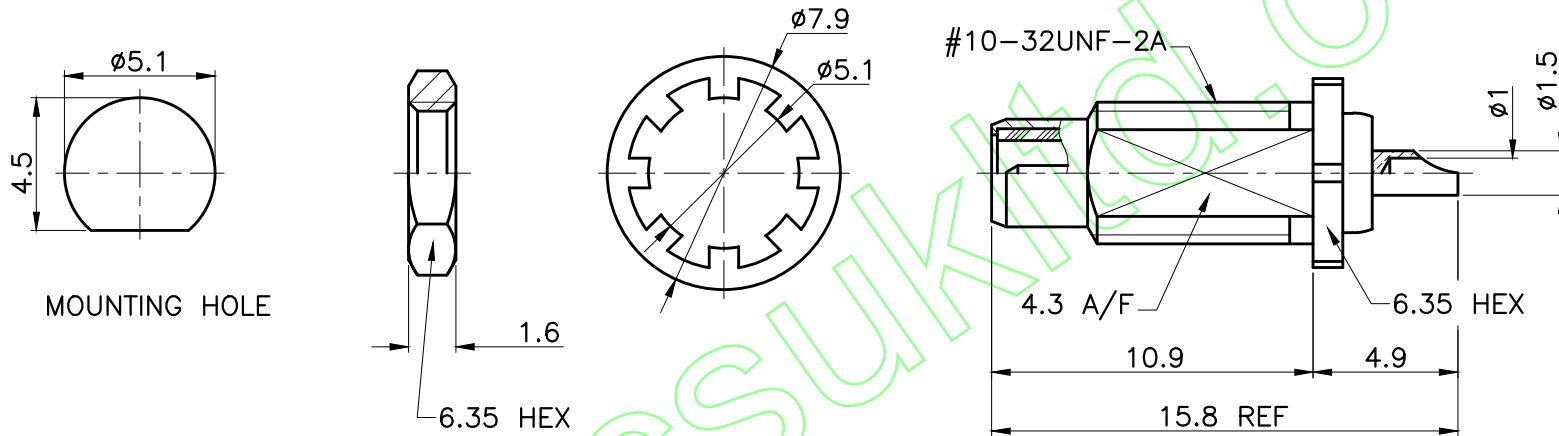

MOUNTING HOLE

1. MAX PANEL THICKNESS=2.4mm

- NOTES: FINISH (PLATING THICKNESS IN MICRO-INCHES)
1. BRASS PER QQ-B-626
 2. GOLD PL 3 MIN OVER NICKEL PL 70 MIN THICK OVER COPPER STRIKE
 3. GOLD PL 30 MIN OVER NICKEL PL 70 MIN THICK OVER COPPER STRIKE
 4. TEFLON MIL-P-19468
 5. BRASS PER QQ-B-613

CONNECTORS CABLES



SPECIALISTS LTD.

TITLE: SMC FEMALE BULKHEAD SOLDER

APRD:	UNLESS OTHERWISE SPECIFIED TOLERANCES 0.5-6 = ±0.2 >6-30 = ±0.4 >30-120 = ±0.6 >120-315 = ±1 >315-1000 = ±1.6 ANGLES = ±5°			
CHKD:		NUT	NPTE 1	NOTE 2
DR:		WASHER	NPTE 5	NOTE 2
PART NO: .	SMCBJSS50	CONTACT PIN	NPTE 1	NOTE 3
DRAWING NO:	037	INSULATOR	NOTE 4	WHITE
DATE: 01/25/13"	UNIT: mm	BODY	NPTE 1	NOTE 2
SHEET: .	SCALE: 4/1	NO. DESCRIPTION	MATERIAL	FINISH