

REVISIONS	
ISS	DESCRIPTION \ DATE

RoHS COMPLIANT

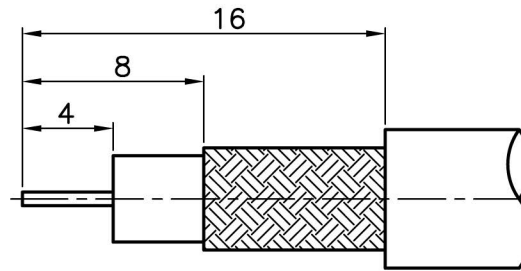

RECOMMENDED  
CABLE STRIPPING DIM'S

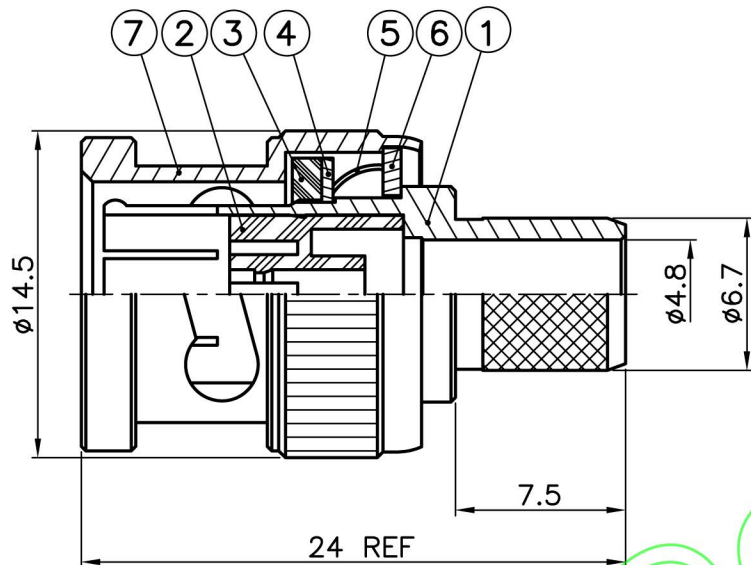
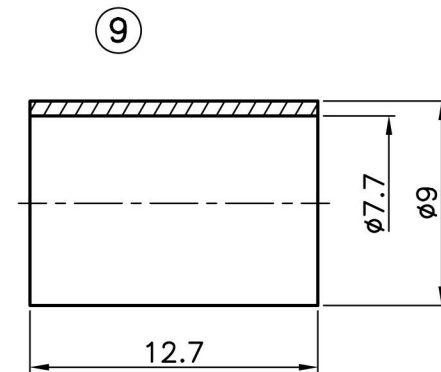
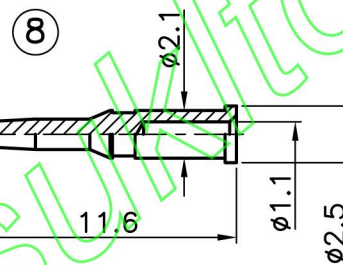

1. CRIMPED FERRULE  
HEX CRIMP SIZE .305"
2. CRIMPED CONTACT PIN  
HEX CRIMP SIZE .068"

**CONNECTORS CABLES**  
**CCS**  
**SPECIALISTS LTD.**

APRD:	UNLESS OTHERWISE SPECIFIED TOLERANCES 0.5-6 = ±0.2 >6-30 = ±0.4 >30-120 = ±0.6 >120-315 = ±1 >315-1000 = ±1.6 ANGLES = ±5°
CHKD:	
DR:	
DATE: 07/05/13	UNIT: mm
SHEET: .	SCALE: 3/1

NO.	DESCRIPTION	MATERIAL	FINISH	SGS REPORT NO
9	FERRULE	BRASS	NICKEL	KA/2005/10527 \ KA/2005/60362
8	CONTACT PIN	BRASS	GOLD	KA/2005/10527 \ KA/2005/30993
7	SHELL	ZINC ALLOY	NICKEL	KA/2005/10528 \ KA/2005/60362
6	WASHER	STEEL	NICKEL	KA/2005/10523 \ KA/2005/60362
5	SPRING	SK-5	NICKEL	KA/2005/10524 \ KA/2005/60362
4	C WASHER	STEEL	NICKEL	KA/2005/10523 \ KA/2005/60362
3	GASKET	PVC	RED	KA/2005/10533
2	INSULATOR	DELFIN	WHITE	KA/2005/10531
1	BODY	BRASS	NICKEL	KA/2005/10527 \ KA/2005/60362

TITLE: BNC MALE CRIMP (75 ohms)  
PART NO: BPCR124  
DRAWING NO: