

REVISIONS		
ISS	DESCRIPTION	DATE

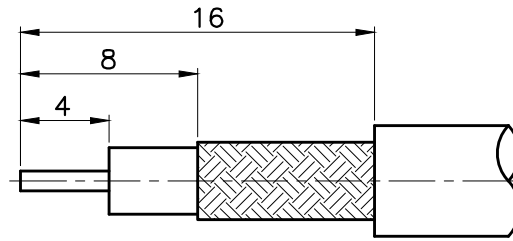

RECOMMENDED
CABLE STRIPPING DIM'S

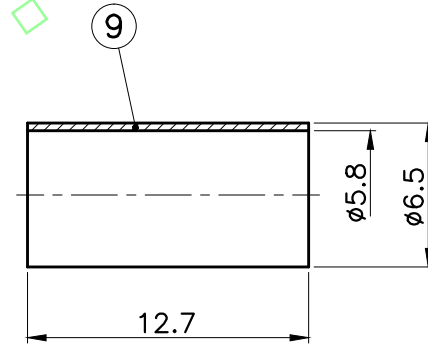
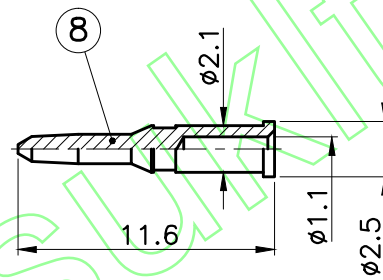
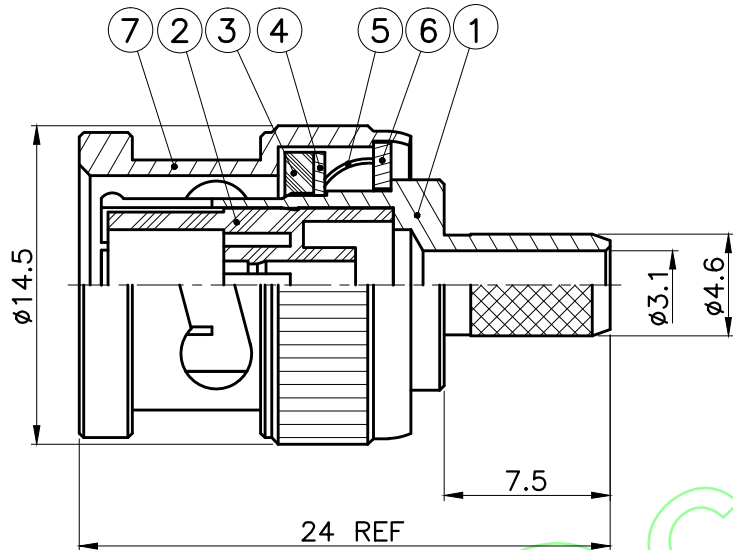

1. CRIMPED FERRULE
HEX CRIMP SIZE .213"
2. CRIMPED CONTACT PIN
HEX CRIMP SIZE .068"

CONNECTORS CABLES



SPECIALISTS LTD.

APRD:	UNLESS OTHERWISE SPECIFIED TOLERANCES 0.5-6 = ±0.2 >6-30 = ±0.4 >30-120 = ±0.6 >120-315 = ±1 >315-1000 = ±1.6 ANGLES = ±5°
CHKD:	
DR:	
DATE: 05/08/08"	UNIT: mm
SHEET: .	SCALE: 3/1

NO.	DESCRIPTION	MATERIAL	FINISH	SGS REPORT NO
9	FERRULE	BRASS	NICKEL	KA/2005/10527\ KA/2005/60362
8	CONTACT PIN	BRASS	GOLD	KA/2005/10527\ KA/2005/30993
7	SHELL	ZINC ALLOY	NICKEL	KA/2005/10528\ KA/2005/60362
6	WASHER	STEEL	NICKEL	KA/2005/10523\ KA/2005/60362
5	SPRING	SK-5	NICKEL	KA/2005/10524\ KA/2005/60362
4	C WASHER	STEEL	NICKEL	KA/2005/10523\ KA/2005/60362
3	GASKET	PVC	RED	KA/2005/10533
2	INSULATOR	DELTRIN	WHITE	KA/2005/10531
1	BODY	BRASS	NICKEL	KA/2005/10527\ KA/2005/60362

TITLE: BNC MALE CRIMP
(FOR RG223)

PART NO: BPCR223

DRAWING NO:

ISO 9001 certificate