

REVISIONS	
ISS	DESCRIPTION \ DATE

RoHS COMPLIANT

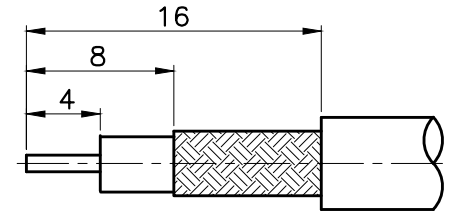

RECOMMENDED CABLE STRIPPING DIM'S

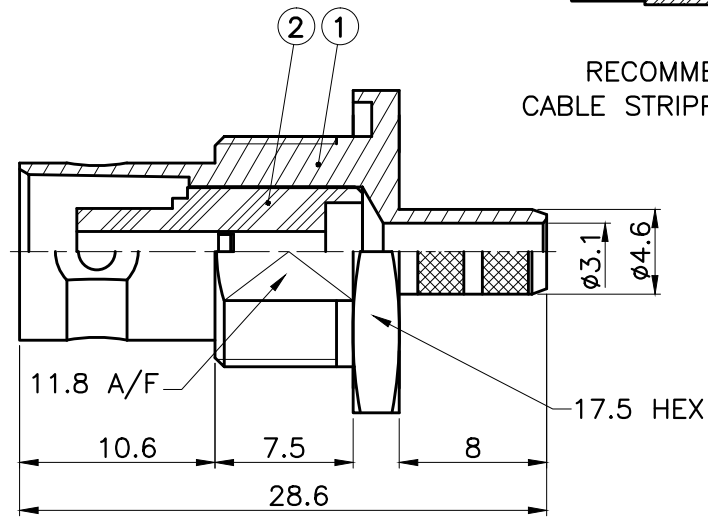
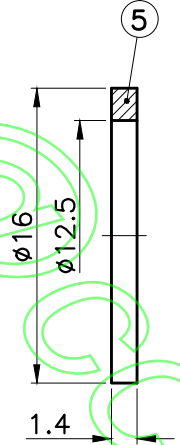
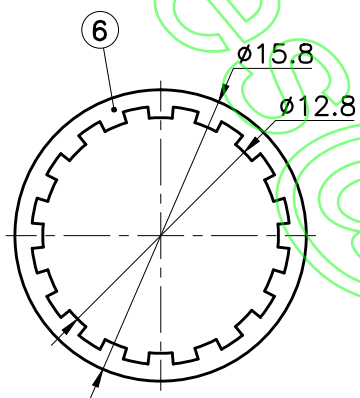
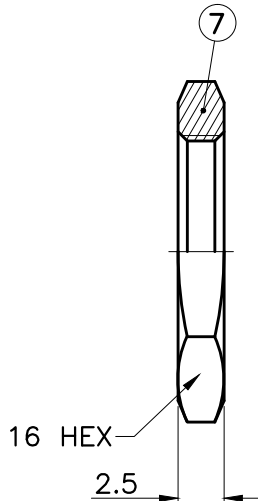

- 1. CRIMPED FERRULE
HEX CRIMP SIZE .213"
- 2. CRIMPED CONTACT PIN
HEX CRIMP SIZE .068" OR SOLDER

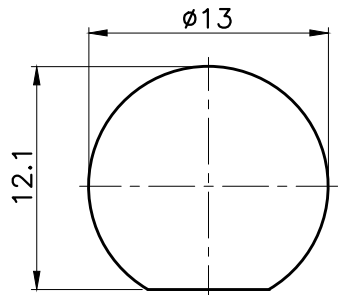

PANEL HOLE

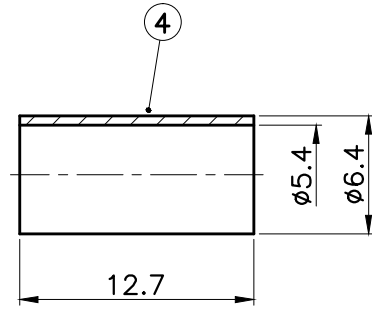
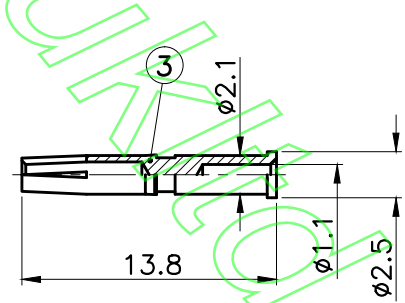

TITLE: BNC FEMALE BULKHEAD CRIMP
(FOR RG58/U)
PART NO: BBJCR58
DRAWING NO:

APRD:	UNLESS OTHERWISE SPECIFIED TOLERANCES 0.5-6 = ±0.2 >6-30 = ±0.4 >30-120 = ±0.6 >120-315 = ±1 >315-1000 = ±1.6 ANGLES = ±5°	7	NUT	BRASS	NICKEL	KA/2005/10527 \ KA/2005/60362
CHKD:		6	WASHER	STEEL	NICKEL	KA/2005/10523 \ KA/2005/60362
DR:		5	GASKET	RUBBER	RED	KA/2005/10530
DATE: 03/12/05"	UNIT: mm	4	FERRULE	BRASS	NICKEL	KA/2005/10527 \ KA/2005/60362
SHEET: .	SCALE: 2.5/1	3	CONTACT PIN	BRASS	GOLD	KA/2005/10527 \ KA/2005/30993
		2	INSULATOR	DELIN	WHITE	KA/2005/10531
		1	BODY	BRASS	NICKEL	KA/2005/10527 \ KA/2005/60362
		NO.	DESCRIPTION	MATERIAL	FINISH	SGS REPORT NO