

order number: J01000A1255

BNC Straight Plug Crimp G1 (RG-58C/U); YR23092 Belden crimp/crimp Professional

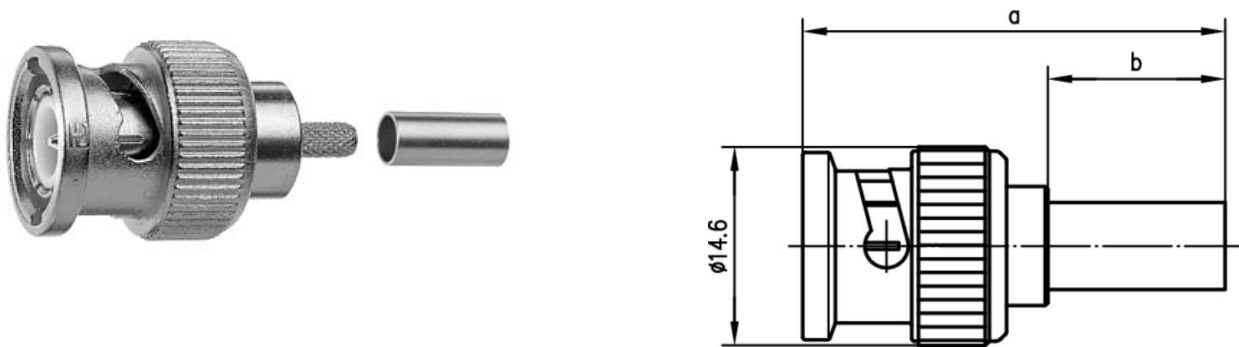

Technical Attributes	
Z	50 Ω
Cable group; cable	G1 (RG-58C/U) HPF 195 WCX195 RG-58C/U 9907 7806A LMR-195 KX 15 CNT-195 YR23092
Remarks	crimp/crimp Professional
Dimensions	a=31, b=13
Assembly	A0205
Crimp die	N01001A0005
MIL-Std.	UG-1785/U

Product description

The BNC series is the most commonly used coax connector. With its bayonet coupling mechanism this connector can be used up to 4 GHz. Both 50 and 75 Ω impedances are available. Connector styles are available for flexible, conformable and semi-rigid cable types. Versions of the BNC connector are available for mounting to printed circuit boards using both through-hole soldered and through-hole press-fit techniques. Both crimp and clamp cable termination processes are used for this series. BNC connectors are used for signal,

data and video transmission applications.

Mating face sealing for BNC connectors between plug and jack (mated) according to IP 54. The classifications are general statements for the relevant series. Individual connectors may deviate from the values shown. If in doubt, please consult our engineers.

Mechanical Characteristics	
Durability (mating cycles)	≥ 500
Material: spring contacts	CuBe2; CuPb1.15Ni1
Material: outer conductor	CuZn39Pb3
Material: other metal parts	CuZn39Pb3
Material: insulators	PTFE; PE PTFE; PE
Material: gaskets	Silicone
Finish: Inner conductor	Cu1Ni2Au0.8
Finish: Outer conductor	Cu2Ni5
Finish: Other metal parts	Cu2Ni5
Mating cycles (gold plating inner conductor)	1000 (0.8 µm)
Material: bayonet (coupling nut)	zinc diecast
Material: coupling spring	copper beryllium
Material: inner conductor	brass
Material: crimp ferrule	copper
Material: insulators	PTFE
Plating finish: Bayonet (Coupling nut)	Nickel
Finish: Crimp ferrule	Nickel

Climatic Characteristics	
Climatic category acc. to IEC 60068 - 1	
Types with PTFE insulator	40/155/21
Types with PE insulator	40/75/21
Temperature range	-65/165

Electrical Characteristics	
Contact resistance inner conductor	≤ 20 mΩ

Contact resistance outer conductor	$\leq 5 \text{ m}\Omega$
Insulation resistance	$\geq 5 \text{ G}\Omega$
Voltage proof	1.5 kV _{eff} /50 Hz
Impedance	50 Ω /(75 Ω)
Return loss: Straight style	$\geq 20 \text{ dB/3 GHz}$ (50 Ω types)
Return loss: Angle style	$\geq 17.7 \text{ dB/3 GHz}$ (50 Ω types)
Working voltage	$\leq 500 \text{ V}_{\text{eff}}/50 \text{ Hz}$
Frequency range up to	4 GHz
Contact resistance inner conductor (initial)	$\leq 0.9 \text{ m}\Omega$
Contact resistance outer conductor	$\leq 0.2 \text{ m}\Omega$
Frequency range	4 GHz
VSWR (50 Ω Types)	$\leq 1.25 / 1 \text{ GHz}$

Standards	
IEC 61 169-8	

Note

Combination connectors and cable clamps can be utilised to create a further number of BNC connector variations.